

Cornerboard Specification Sheet

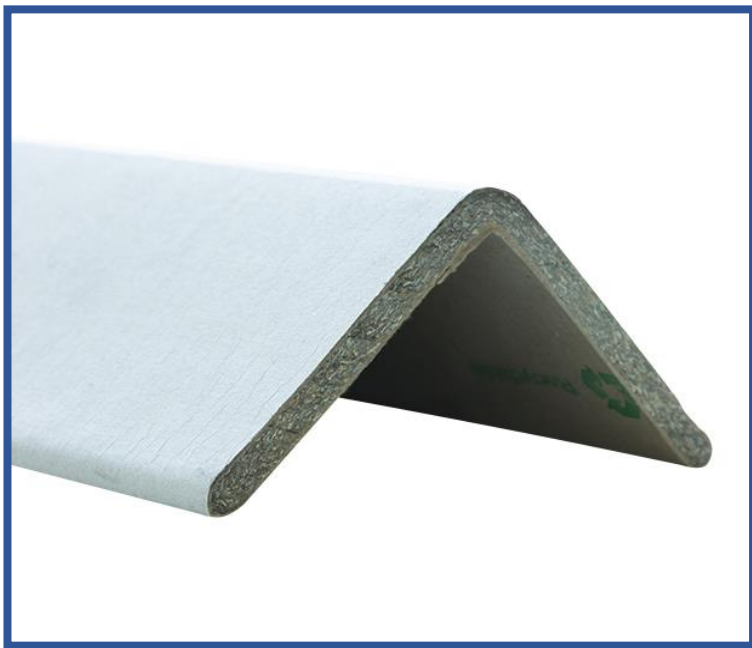

Description

A high-strength, moisture resistant corner post made of recycled paper and plastic formed into a rigid right angle. Predominantly used to brace and support pallets. This product can be exposed to moisture for long periods of time without deteriorating. This makes it ideal for products that are refrigerated, frozen, or exposed to high humidity or the elements such as being shipped on flatbed trucks, stored outdoors etc. It is also used extensively for export as it gives the strength and moisture protection required for extended periods of time at sea.

Composition

Wrapped, Cellulose/Polyethylene based composite

Sizes (mm)

Length (D): 50 – 6000mm

A	B	C
35	35	2.6/3/4/5/6
40	40	2.6/3/4/5/6
45	45	2.6/3/4/5/6
60	60	2.6/3/4/5/6
75	75	2.6/3/4/5/6
100	100	2.6/3/4/5/6

Tolerances

Legs:	+/- 5mm*
Thickness:	+/- 0.4mm*
Length:	+/- 10mm
Angle:	+/- 10°
(*Average of 2 legs)	

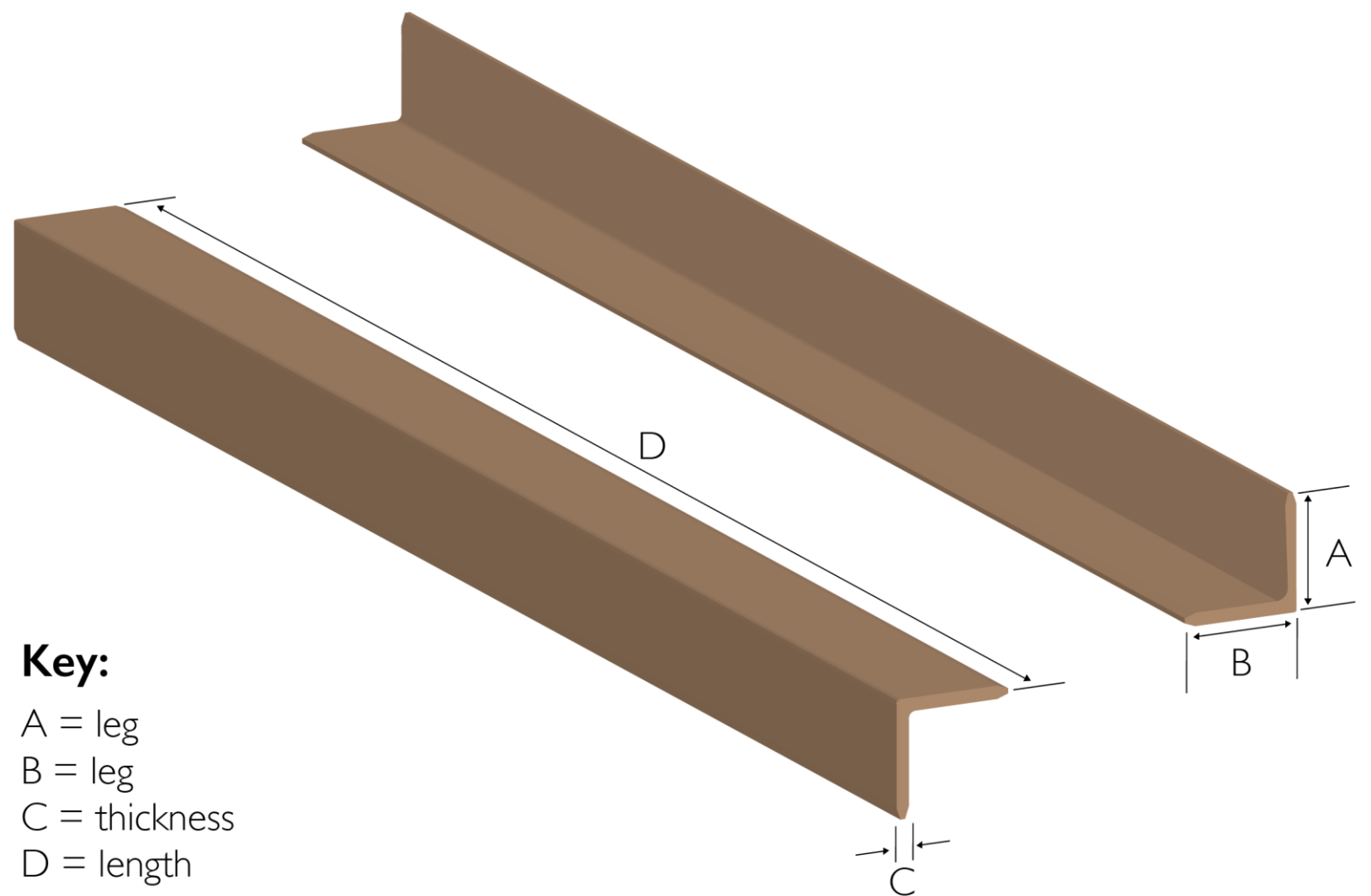

Key:

- A = leg
- B = leg
- C = thickness
- D = length

Available Options

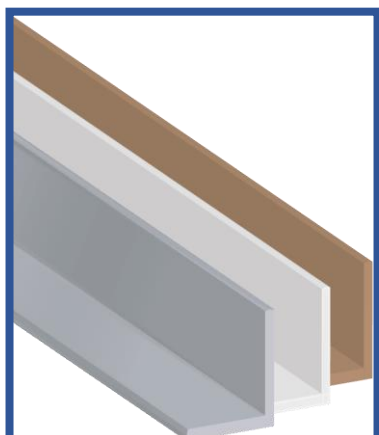

Standard Brown or White outer wrap. Silver (aluminium) wrap available on some sizes.

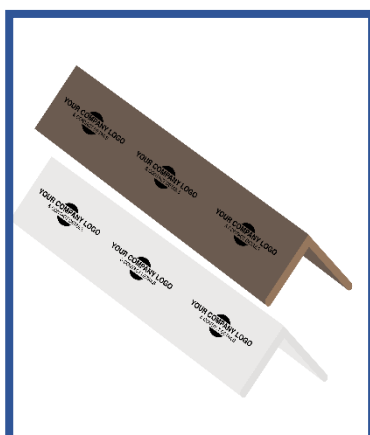

One colour printing to promote your brand or provide information

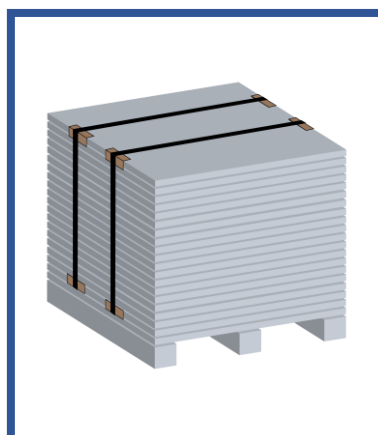

Sawn to short lengths for strapping protection



Type "R" Reinforced for extra strength

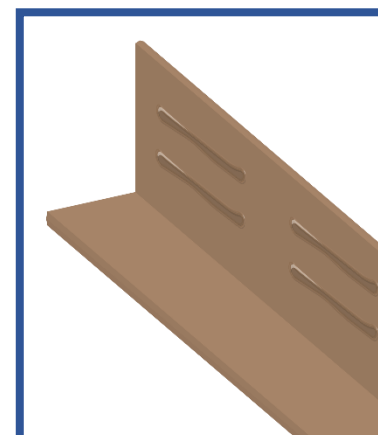

Hot melt glue dots or continuous strips (One or two legs)

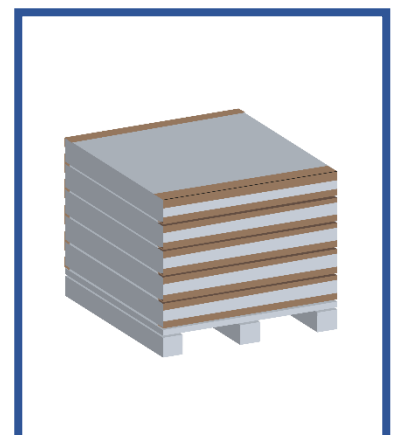

Long lengths up to 6000mm



www.angleboarduk.co.uk
uksales@angleboarduk.co.uk
01384 253290