

# Angleboard Specification Sheet



## Description

Multiple plies of recycled paper, laminated together and formed into a rigid right angle. Used to brace and support, prevent crushing from shrink wrap and protect edges of product from damage caused by storage, transit or strapping. Warehouse storage capacity can be greatly enhanced and transport costs reduced with the ability to stack pallets.

## Composition

100% Recycled paper, fully wrapped  
Environmentally friendly PVA glue  
Fully Recyclable

## Sizes (mm)

Length (D): 50 – 6000mm

A	B	C
25	25	2
35	35	2/3
50	50	2/3/4/5
60	60	2/3/4/5/6
70	70	2/3/4/5/6
80	80	2/3/4/5/6

Note: 0.5mm increments on thickness and offset legs available on some sizes

## Tolerances

Legs:	+/- 5mm*
Thickness:	+/- 0.4mm*
Length:	+/- 5mm
Angle:	+/- 10°
(*Average of 2 legs)	

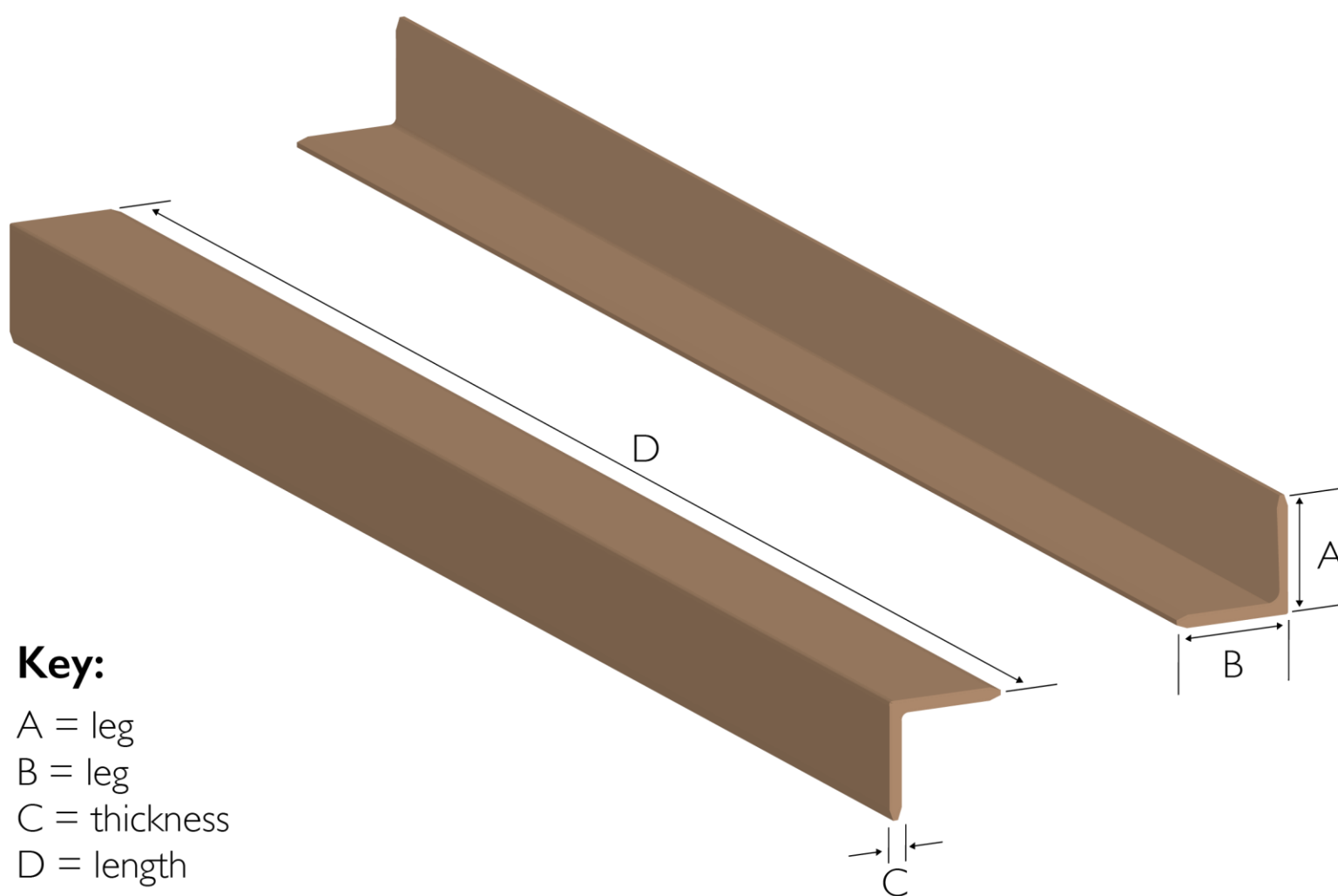

## Key:

A = leg  
B = leg  
C = thickness  
D = length

## Available Options

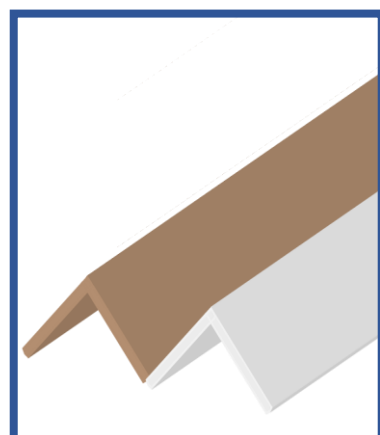

Standard Brown or White outer wrap

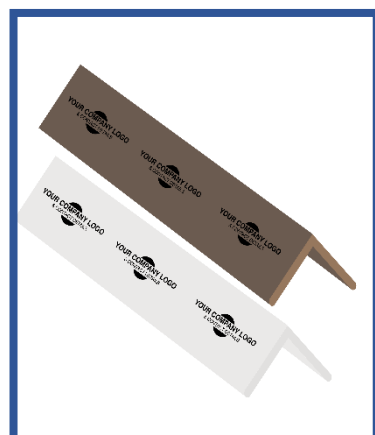

One colour printing to promote your brand or provide information

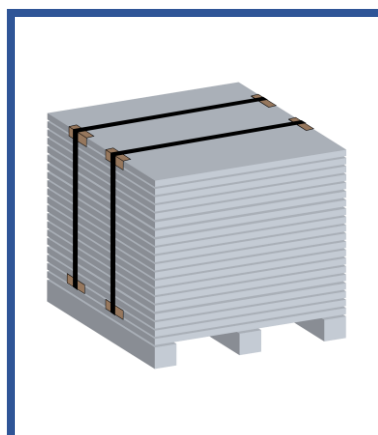

Sawn to short lengths for strapping protection

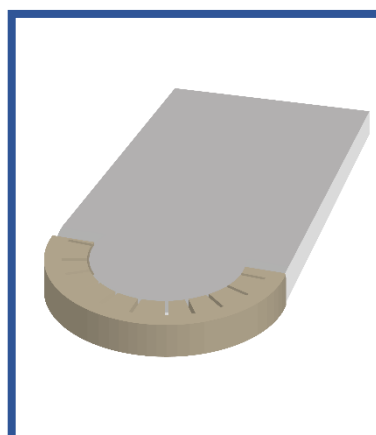

Notched on one leg to protect the edge of a curved object

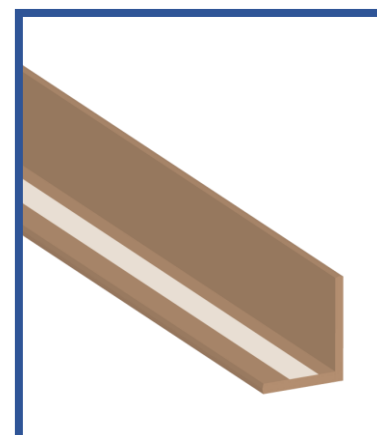

Self adhesive tape (One or two legs)

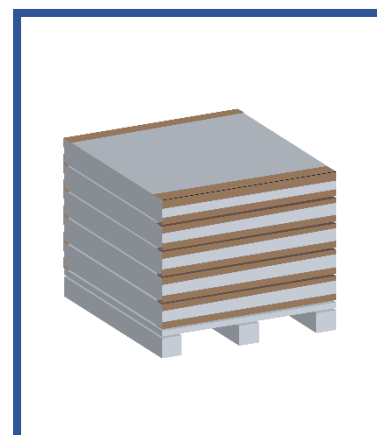

Long lengths up to 6000mm ideal to protect items such as worktops and steel sheets.



[www.angleboarduk.co.uk](http://www.angleboarduk.co.uk)  
[uksales@angleboarduk.co.uk](mailto:uksales@angleboarduk.co.uk)  
**01384 253290**